

Adsorber MA-RV series

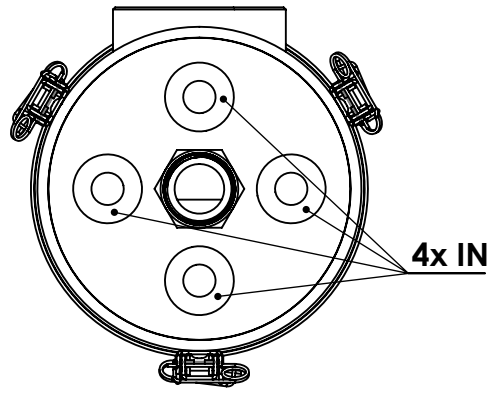
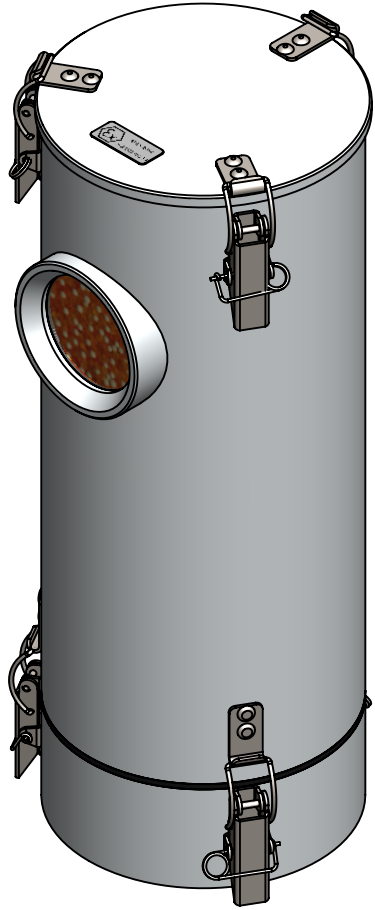
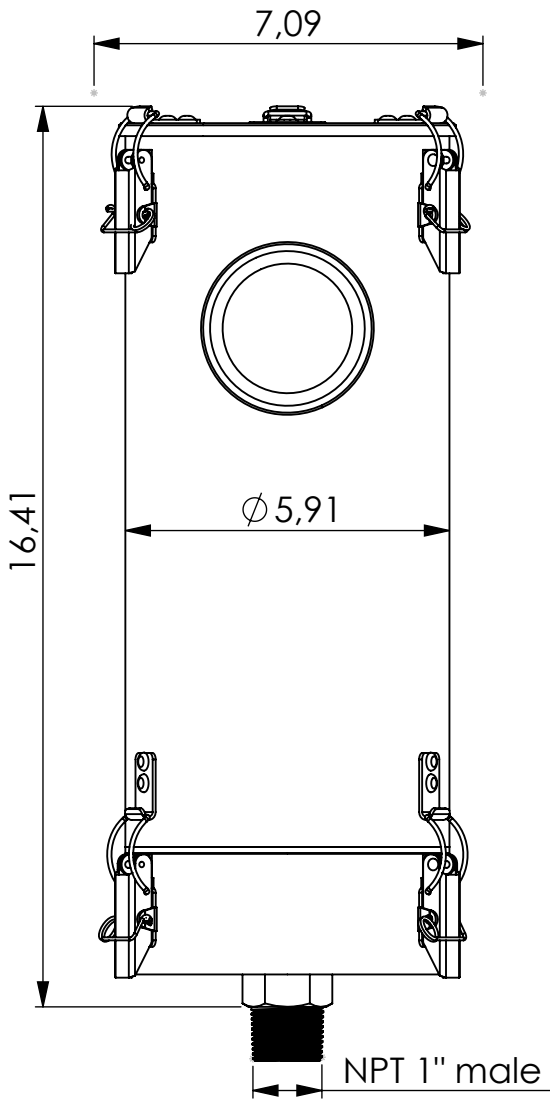

Product Code	MA	-	RV	-	5L	-	F	-	40	-	P3	-	XC	-	N1m
	Adsorber type		Refillable cartridge + valves		Size		FKM seals		Check valves 4 IN 0 OUT		Paper filter 3 micron		Adsorbent GIEBEL Xdry® & carbon		Connection for System NPT 1" male

Housing materials:	Aluminum		
GIEBEL Xdry® (lb):	7.28	Color-change capacity (floz):	39.1
Total weight (lb):	14.98		

NAME:
Adsorber MA-RV 5L IN N1"m
MA-RV_5L_F_40_P3_XC_N1m



GIEBEL FilTec Inc.
www.giebel-adsorber.com
info.us@gf-dry.com

Article no.:	08.0003.44	Status freigabe	Format A4
		Maßstab	Blatt / von
		1:3.5	1 / 1

Weitergabe sowie Vervielfältigung dieses Dokuments, Verwertung und Mitteilung seines Inhalts sind verboten, soweit nicht ausdrücklich gestattet. Zuwiderhandlungen verpflichten zu Schadensersatz. Alle Rechte für den Fall der Patent-, Gebrauchsmuster- oder Geschmacksmusterreife vorbehalten.